

RFB95

FULLY SPLIT CARTRIDGE SEAL:

- ONLY TWO HALVES TO ASSEMBLE
- ALL INTEGRAL COMPONENTS MOUNTED ON COMMON SPLIT SLEEVE
- STATIONARY DESIGN FOR MAXIMUM ALIGNMENT
- CARTRIDGE STYLE SETTING CLIPS
- ASSEMBLED OUTSIDE THE STUFFING BOX
- SPRINGS PROTECTED BY ORING
- POSITIVE SET SCREW DRIVE
- FULLY PRESSURE TESTED AT THE FACTORY
- UNIVERSAL GLAND DESIGN
- EASY IMPELLOR ADJUSTMENTS WITHOUT REMOVAL
- METRIC SIZES AVAILABLE

STANDARD MATERIALS:

FACES: CARBON VS. SILICON CARBIDE

SILICON CARBIDE VS. SILICON CARBIDE

ELASTOMERS: VITON, EPR, AFLAS

SPRINGS: HASTELLOY® C276

METALLURGY: 316SS

OPERATING PARAMETERS:

SHAFT SPEEDS TO 5,000 FPM

TEMPERATURES TO 350°F (175° C)

PRESSURES TO 250 PSI (17 BAR)

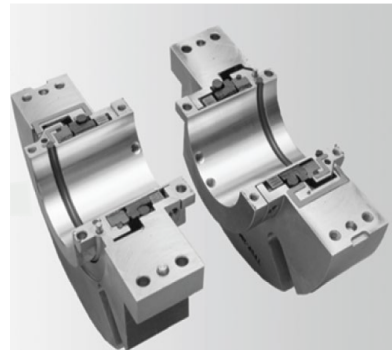
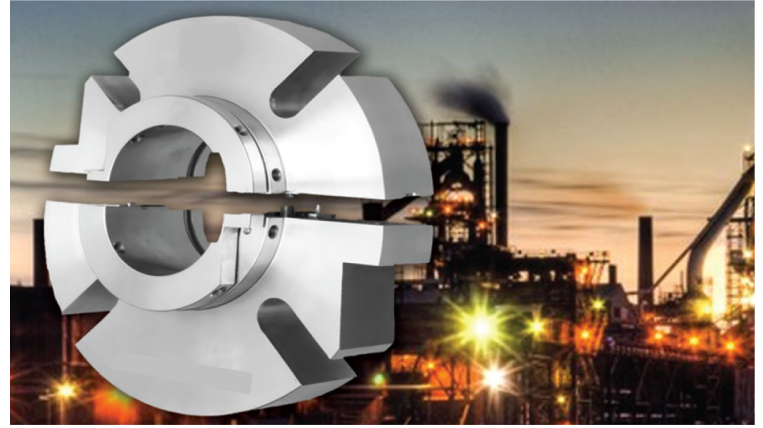

Cross Section

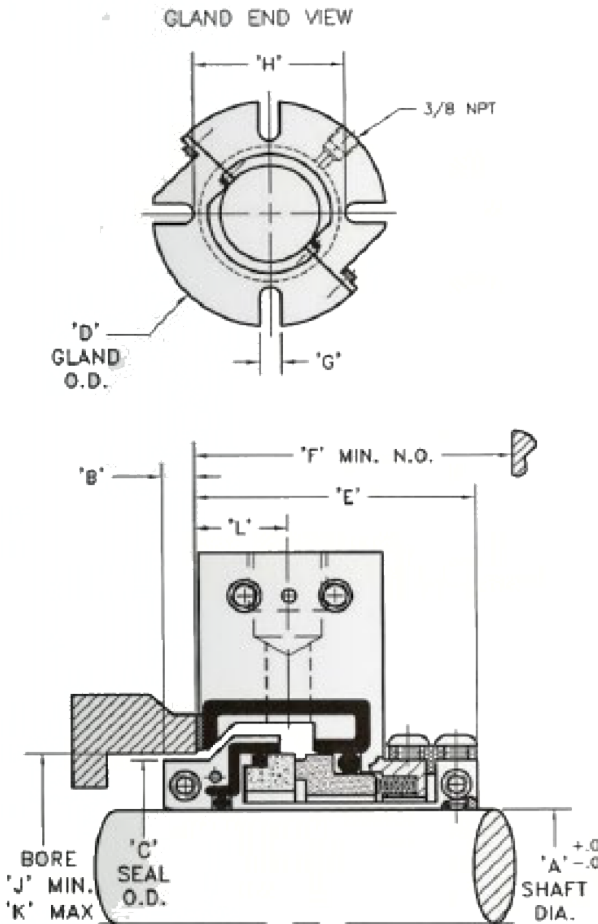

Size	A	B	C	D	E	F	G	H	J	K	L
-24	1.5	0.25	2.187	5.25	2.125	2.5	0.562	3.125	2.25	2.625	0.656
-27	1.687	0.25	2.437	5.5	2.125	2.5	0.562	3.375	2.5	2.875	0.656
-28	1.75	0.25	2.437	5.5	2.125	2.5	0.562	3.375	2.5	2.875	0.656
-30	1.875	0.25	2.562	5.5	2.125	2.5	0.562	3.344	2.625	3	0.656
-31	1.937	0.25	2.625	5.44	2.125	2.5	0.562	3.563	2.887	3.125	0.656
-32	2	0.25	2.687	5.44	2.125	2.5	0.562	3.563	2.75	3.125	0.656
-34	2.125	0.25	2.812	6	2.125	2.5	0.687	3.688	2.875	3.375	0.656
-35	2.188	0.25	2.937	6.25	2.125	2.5	0.687	3.813	3	3.375	0.656
-36	2.25	0.25	3.062	6.25	2.125	2.5	0.687	3.937	3.125	3.5	0.656
-38	2.375	0.25	3.187	6.25	2.125	2.5	0.687	4.062	3.25	3.5	0.656
-39	2.438	0.25	3.312	6.44	2.125	2.5	0.687	4.125	3.375	3.625	0.656
-40	2.5	0.25	3.312	6.44	2.125	2.5	0.687	4.125	3.375	3.625	0.656
-42	2.625	0.25	3.347	6.44	2.125	2.5	0.687	4.438	3.5	3.875	0.656
-43	2.688	0.25	3.562	7.82	2.125	2.5	0.687	4.438	3.625	4.125	0.656
-44	2.75	0.25	3.562	7.82	2.125	2.5	0.687	4.438	3.625	4.125	0.656
-46	2.875	0.25	3.687	7.82	2.125	2.5	0.687	4.812	3.812	4.25	0.656
-47	2.938	0.25	3.812	7.88	2.125	2.5	0.687	4.938	3.937	4.375	0.656
-48	3	0.25	3.812	7.88	2.125	2.5	0.687	4.938	3.937	4.375	0.656
-52	3.25	0.281	4.188	8.25	2.437	2.812	0.812	5.188	4.25	4.75	0.812
-54	3.375	0.281	4.312	8.25	2.437	2.812	0.812	5.313	4.375	4.875	0.812
-55	3.438	0.281	4.437	8.5	2.437	2.812	0.812	5.437	4.5	5	0.812
-56	3.5	0.281	4.437	8.5	2.437	2.812	0.812	5.437	4.5	5	0.812
-58	3.625	0.281	4.562	8.63	2.437	2.812	0.812	5.562	4.625	5.125	0.812
-60	3.75	0.281	4.625	8.82	2.437	2.812	0.812	5.688	4.687	5.125	0.812
-62	3.875	0.281	4.812	8.82	2.437	2.812	0.812	5.813	4.875	5.25	0.812
-64	4	0.281	4.937	8.82	2.437	2.812	0.812	5.813	5	5.375	0.812
-68	4.25	0.281	5.188	9.25	2.437	2.812	0.812	6.063	5.25	5.75	0.812
-70	4.375	0.281	5.312	9.25	2.437	2.812	0.812	6.437	5.375	5.875	0.812
-72	4.5	0.281	5.408	9.69	2.437	2.812	0.812	6.5	5.5	6	0.812
-76	4.75	0.281	5.658	9.75	2.437	2.812	0.812	6.938	5.75	6.25	0.812
-79	4.938	0.375	6.188	10.75*	3.062	3.812	0.937	7.312	6.312	6.75	0.923
-80	5	0.375	6.188	10.75*	3.062	3.812	0.937	7.312	6.312	6.75	0.923
-82	5.125	0.375	6.375	11.00*	3.062	3.812	0.937	7.812	6.5	7.25	0.923
-84	5.25	0.375	6.375	11.00*	3.062	3.812	0.937	7.812	6.5	7.25	0.923
-88	5.5	0.375	6.688	11.50*	3.062	3.812	0.937	7.813	6.812	7.375	0.923
-92	5.75	0.375	6.938	12.00*	3.062	3.812	0.937	8.156	7.062	7.625	0.923
-100	6.25	0.375	7.438	12.50*	3.062	3.812	0.937	8.656	7.562	8.125	0.923
-104	6.5	0.375	7.688	12.25*	3.062	3.812	0.937	8.813	7.812	8.375	0.923
-108	6.75	0.375	7.938	12.50*	3.25	4	0.937	9.312	8.062	8.625	0.923
-112	7	0.375	8.188	12.75*	3.25	4	0.937	9.562	8.312	8.75	0.923
-136	8.5	0.375	9.688	14.25	3.25	4	1.000	11	9.812	10.25	0.923



www.cardonsales.com

(337) 839-1704